

VWFS95-L

FULL SERVICE VIDEO WALL MOUNT

FOR 70"-95" SCREENS, LANDSCAPE

VWFS95-L is designed for easy and fast installation of video walls with large 70"-95" screens. Micro-adjustment allows smooth alignment of screens without the use of tools. Precise and dedicated spacers eliminate the need to perform calculations and measurements at the installation site. The retractable mechanism allows you to extend the screen forward and tilt it upwards as well as rest the weight of the screen on the supports for easy access for installation and safe servicing. VWFS95-L is equipped with a lock against uncontrolled structure opening, ensuring comfort of use and safety. A well-configured video wall guarantees high image quality in any room.



FEATURES

- 8-point micro-adjustment ensures smooth alignment of screens without the use of tools
- The retractable mechanism allows you to extend the screen forward and tilt it upwards as well as rest the weight of the screen on the supports for easy safe operation
- The open design of the product provides full access to cabling, and the supplied ties facilitate cable management
- Mounting holes and carefully selected spacers eliminate the need for calculations on site
- The anti-theft padlock enhances safety of the installation in public areas

PRODUCT SPECIFICATIONS

Short index	VWFS95-L
Category	Video Wall Mounts
Product group	Video Wall & Menu Board Mounts
Colour	Black
Warranty	Limited 5-years
Minimum screen size	70"
Maximum screen size	95"
Maximum load	130 kg
Forward tilting	-20°
VESA Mounting Compatibility	100x100 up to 800x600

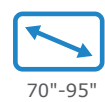

Securing the screen against falling with screws



Minimalistic design and functionality



Wide range of VESA mounting standards

FRONT VIEW

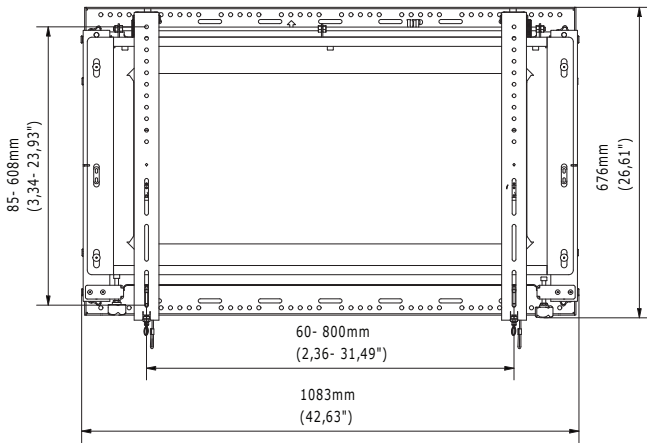

TOP VIEW

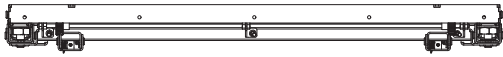

SIDE VIEW

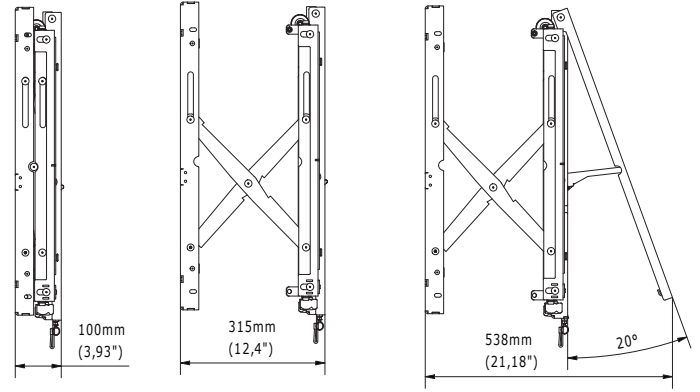

REAL VIEW

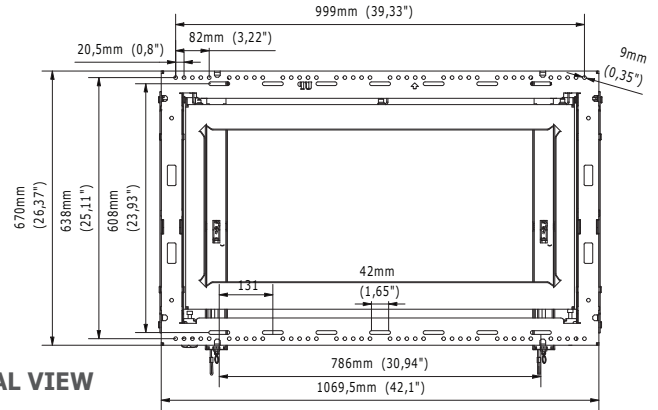

TECHNICAL SPECIFICATIONS

Product dimensions	W: 1083 mm D: 100 mm H: 676 mm (W:42,64" D:3,94" H:26,61")
Product weight	32 kg (70,55 lb)
Max. distance from the surface	315 mm (12,40")
Min. distance from the surface	100 mm (3,94")
Max. mounting pattern	800 mm x 608 mm
Min. mounting pattern	60 mm x 85 mm

LOGISTICS DATA

SAP INDEX	EAN CODE	COLOUR	PACKAGE DIMENSIONS	PACKAGE WEIGHT
WUSC-VWFS95-L	5908252968756	BLACK	1100 x 890 x 110 mm 43,31 x 35,04 x 4,33"	32,5 kg 72 lb

HS Code (Harmonized System): 732690, HTS Code (Harmonized Tariff Schedule): 7326909890, Country of Origin: Poland

ACCESSORIES AND RELATED PRODUCTS



VWFS65-L



VWFS95-P



VWPOP95-L



VWFX95-L